

Waldor 50, Tile-a-Door+, Maghatch, Combihatch

Access covers for use in ceilings and tiled wall surfaces

Steel access panels for accessing services within walls and ceilings. The Maghatch and Combihatch products are designed to accept a paint finish and are supplied ready primed, while the Tile a Door+ and Waldor 50 are suitable for tiled finishes up to 12mm thick.

Features and benefits

- Precision made using cnc machinery to ensure accurate and unobtrusive installation.
- All products can be custom made to the mm to suit actual site or tile sizes.
- Suitable for new build and refurbishment projects.
- Easy to open and maintenance free.
- One hour fire rating available on Combihatch series.
- All products except the Maghatch available with a security lock.
- Manufactured from corrosion resistant steel.
- Supplied quickly and economically.
- Quality control to BS EN ISO 9001: 2000
- Fire ratings assessed to BS 476: Part 20: 1987 up to 1 hour integrity.

Combihatch

for access through walls and ceilings

Introduction

The Howe Green Combihatch access panel is designed to give access to concealed services within walls and ceilings.

Composition and manufacture

Manufactured from 1.2mm electro-galvanised mild steel, powder coated to RAL 9003 matt finish.

Options

The doors can be fitted with either budget or security locks. The outer frames can incorporate a plaster bead or picture frame surround. Brushed stainless finish.

1 Hour fire rating to BS476: Part 22: 1987

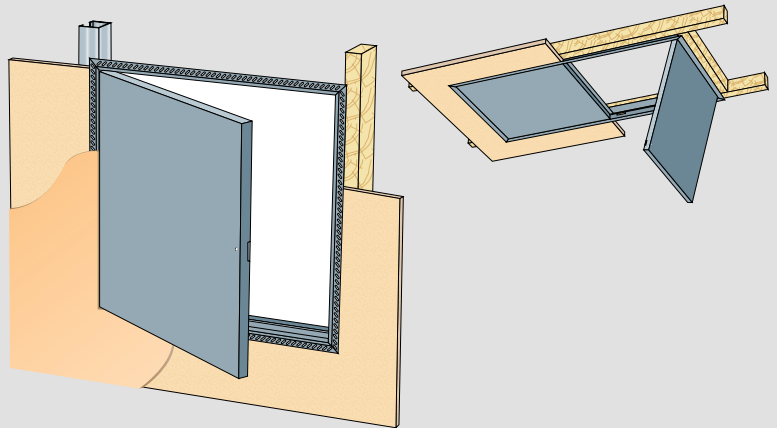

Cross section of Combihatch (scale 1:2)

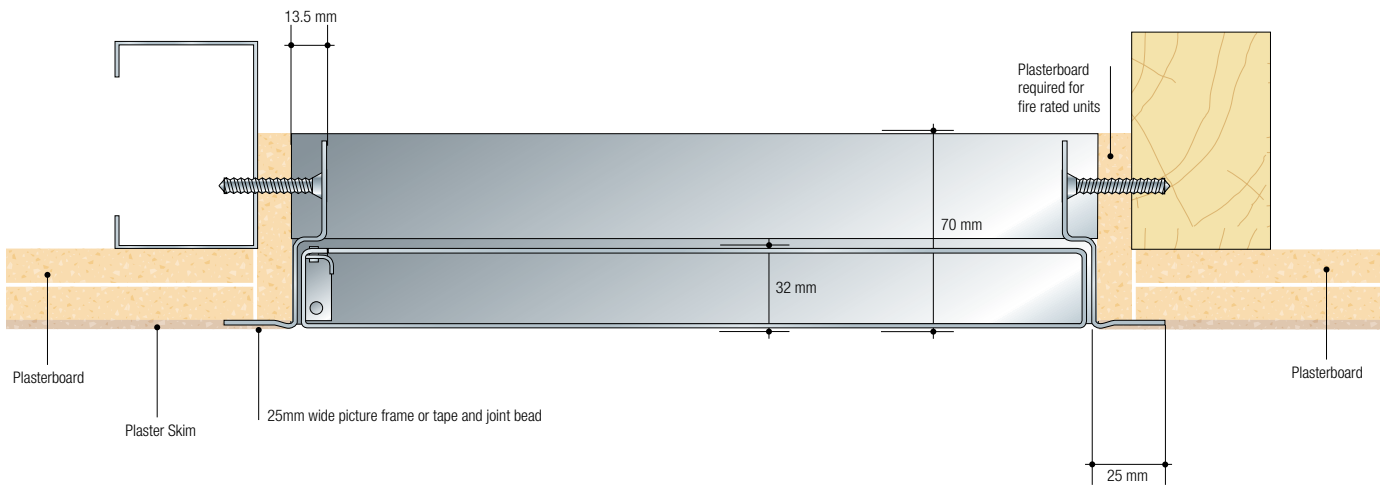

Typical specification clause

Wall/ceiling access panels shall be Howe Green Ltd Combihatch series manufactured from electroplated steel with a concealed hinge and fitted with a budget/security lock*, the outer frame is to be fitted with a picture frame/plaster bead*. The door panel shall be metal faced and powder coated to RAL 9003 matt finish. Cut out sizes shall bemm Xmm. Hatches are to be fire rated for 60 minutes to BS 476: Part 20: 1987*. All to be manufactured and supplied by Howe Green Ltd, Marsh Lane, Ware, Herts, SG12 9QQ UK, Tel. +44 (0)1920 463230 and installed in accordance with the manufacturers details and site work guide.

* Delete as appropriate

For Walls

Single or double leaf non fire rated

Minimum leaf size 300 X 300mm
Maximum leaf size 1000 X 1000mm

Single leaf fire rated

Minimum leaf size 300 X 300mm
Maximum leaf size 1026H X 662mmW or 756H X 756mmW (Any leaf within these aspect ratios can be used as long as the dimensions are not exceeded)

Double leaf fire rated

Minimum leaf size 300 X 300mm
Maximum leaf size 1026H X 600mmW

For Ceilings

Single or double leaf non fire rated

Minimum leaf size 300 X 300mm
Maximum leaf size 1000 X 1000mm

Single leaf fire rated

Minimum leaf size 300 X 300mm
Maximum leaf size 900 X 600mm

Size

All panels are manufactured to order in 1mm increments between the minimum and maximum sizes listed. Cut out sizes = door size + 10mm (for fire rated units, door size + 35mm).

Tile-a-Door+

for access through tiled wall surfaces

Introduction

The Howe Green Tile-a-Door+, removable wall access panel has been designed to give easy economical access to concealed services. The units are supplied ready to tile, accepting up to a 10mm thick finish.

Composition and manufacture

Manufactured from mild steel electro-galvanised sections and fitted with magnetic latches.

Options

Covers can be fitted with either a budget/security lock or magnetic latch if required.

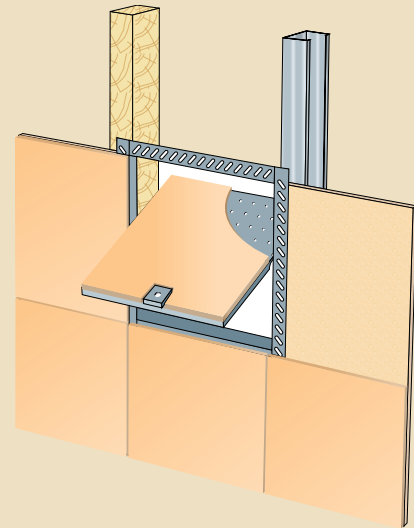

Cross section of Tile-a-Door+ (scale 1:2)

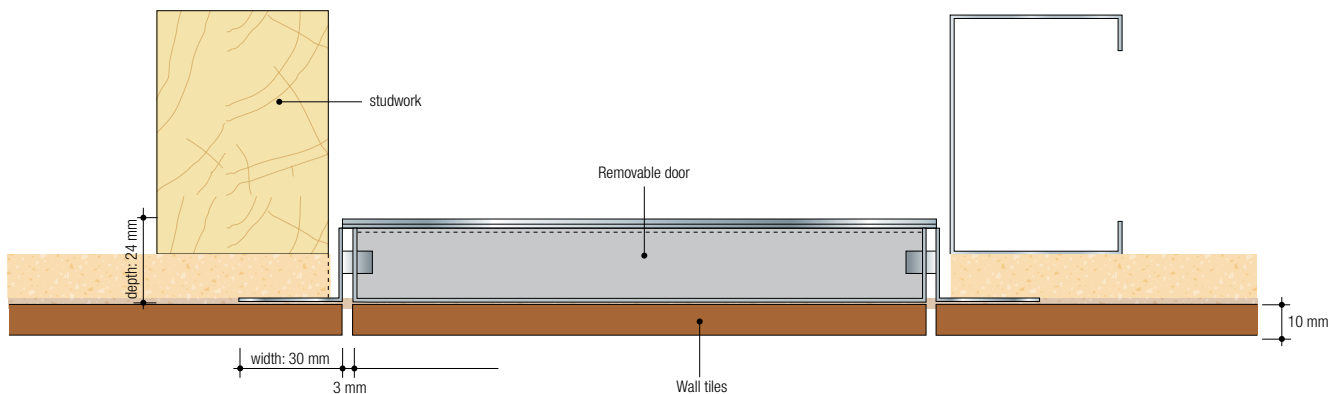

Typical specification clause

Wall access panels shall be Howe Green Ltd Tile-a-Door+, manufactured from electro-galvanised mild steel with a concealed pivot, the panels are to be fitted with a budget/security lock*. Overall door sizes shall bemm Xmm. All to be manufactured and supplied by Howe Green Ltd, Marsh Lane, Ware, Herts, SG12 9QQ Great Britain, Tel. 01920 463230 and installed in accordance with the manufacturers details and site work guide.

* Delete as appropriate.

Size

All panels are made to order in 1mm increments to suit the tile module. The maximum area of door available is 0.16m² e.g. 400 X 400mm or 600 X 260mm. There is a nominal gap between cover and frame of 3mm. The size of the cut out required in the wall is the door size + 15mm.

Maghatch

for access through wall surfaces

Introduction

The Howe Green Maghatch access panel is designed to give access to concealed services within walls such as valves or rodding points. The panel frame is simply bonded to the wall using a panel adhesive.

Composition and manufacture

Manufactured from 1.2mm thick zinc coated steel finished with a primer coat ready to accept a paint finish.

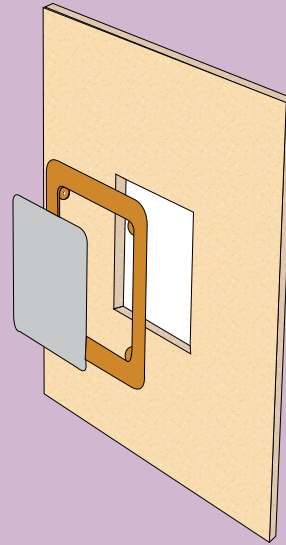

Cross section of Maghatch (Scale 1:2)

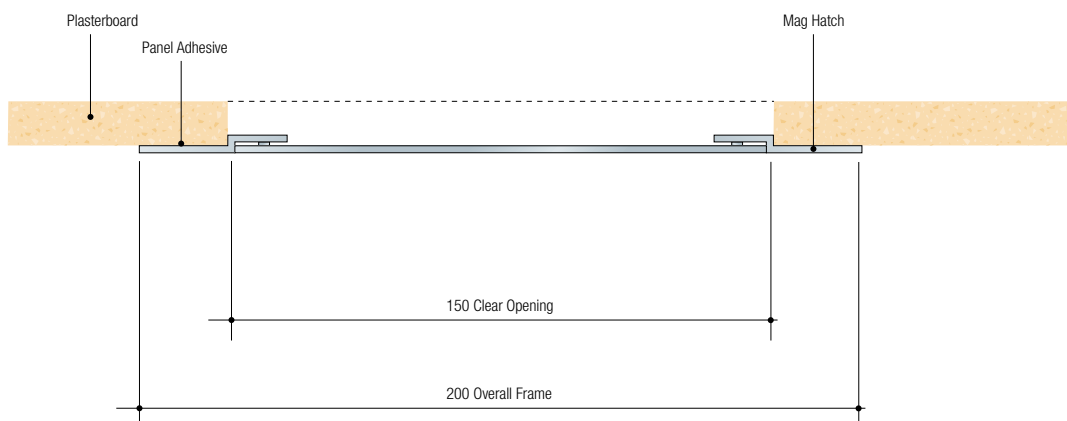

Typical specification clause

Wall access panels shall be Howe Green Ltd Maghatch series manufactured from electroplated steel with a primer finish. Cut out sizes shall bemm Xmm. All to be manufactured and supplied by Howe Green Ltd, Marsh Lane, Ware, Herts, SG12 9QQ UK, Tel. +44 (0)1920 463230 and installed in accordance with the manufacturers details and site work guide.

Sizes

The standard size is 210 X 210mm overall the outer frame with a 150 X 150mm removable panel.

Special sizes are available to order with a maximum removable panel size of 250 X 250mm

Installation guide and sitework details

For Maghatch, Combihatch, Tile-a-Door+ and Waldor 50

These details are intended as a general guide to correct installation - it is appreciated that site practice can vary depending on the type of materials used etc.

Further advice is always available from our technical department who can be contacted between the hours of 9 am and 5.30 pm on 01920 463230, or alternatively you can email them at info@howegreen.co.uk.

Maghatch

Place the face of the outer frame against the wall, and mark the hole position. Remove the outer frame and extend the marked lines to the corners to form a square or rectangular shape for the cut out.

Cut a hole in the wall board using a suitable saw.

Apply proprietary panel adhesive around opening then place outer frame into position.

The outer frame and cover can now be decorated separately and allowed to dry. Once dry the cover can be put into place to complete the installation.

Combihatch

The construction of the opening should be as follows, for non fire rated units the "cut out" in studwork should be fully trimmed. For fire rated units again the aperture should be fully trimmed, though for metal "C stud" the aperture surround should be boxed out using twin sections of "C stud". All box sections of 60 minute assemblies must be infilled with plasterboard to mitigate against an excessive distortion of the supporting construction.

Remove the doors from the outer frame by releasing the spring loaded hinge pins, for non fire rated assemblies the outer frame should be placed into position and secured using 8 X 38mm steel screws at 200mm centres using holes provided, taking care not to distort the frame. For fire rated assemblies the "cut out" aperture should be lined with 12.5mm plasterboard, then the outer frame should be positioned and then secured using 8 X 50mm steel screws at 200mm centres using holes provided, taking care not to distort the frame.

If the frame incorporates a plaster bead, the wall/ceiling should now be skimmed.

Once the frame installation is complete a 6mm drill should be run through the hinge pin holes in the frame to ensure that the hinge pins will enter by at least 6mm.

The door should now be re-fitted and closed and any final decoration should be completed.

Tile a Door+

If there is no pre-formed opening for the Tile a Door+, mark the area of wall where the opening is required by projecting the tile grid lines. Once marked, the hole should be cut allowing an extra 6mm clearance all round. If fitting to thin sheet or plasterboard, it is advisable to stiffen the cut edges with studwork.

Fit the frame into position using either a suitable adhesive or screws, ensuring that the magnets or lock are at the bottom of the panel.

Tile the panel and surrounding area as normal. Please note that if the opening in the wall was preformed then the tiling would have to be set out from the Tile a Door+. Once the adhesive has set the tiling should be grouted in as normal, leaving out the grout line around the door.

To open the door, release the lock if fitted, then push the top of the panel inwards. Once the base of the door can be gripped, slide the panel inwards and up to release it from the pivot points.

The door can now be lifted out and stored safely.

Waldor 50

If there is no pre-formed opening for the Waldor 50, mark the area of the wall where the opening is required by projecting the tile grid lines. Once marked the hole should be cut allowing an extra 5mm clearance all round. If fitting to thin sheet or plasterboard, the opening should be trimmed using suitable studwork.

Fasten the fixing brackets to the top and bottom of the access cover outer frame, using the screws provided. The access cover can now be fixed top and bottom to the wall or studwork through the previously attached brackets.

If edge trims or a security lock has been specified then the face of the door should be set back 12mm from the face of the surrounding tiling.

Once the frame has been secured and the hatch closed, proceed to tile over the door face and complete the surrounding wall finish. Take care to ensure that a 2mm joint between the door and the surrounding tiles is maintained.

Once the tiled finish has set, carefully open the door to ascertain whether any door adjustment is required to maintain a constant door surround gap. Should any adjustment be needed open the door fully, then release both of the securing screws holding the hinge block (5mm Allen key ; supplied) found on the inside rear edge of the frame. Carefully lift/move the door to the desired position, and then re-fasten the hinge block to the new position. Re-close the door and check the door gap, re-adjust as necessary.

Should any of the seals, bolts or other removable components be damaged or missing they are available for replacement.